

HEAVY DUTY LINE VAC™ INSTALLATION & MAINTENANCE

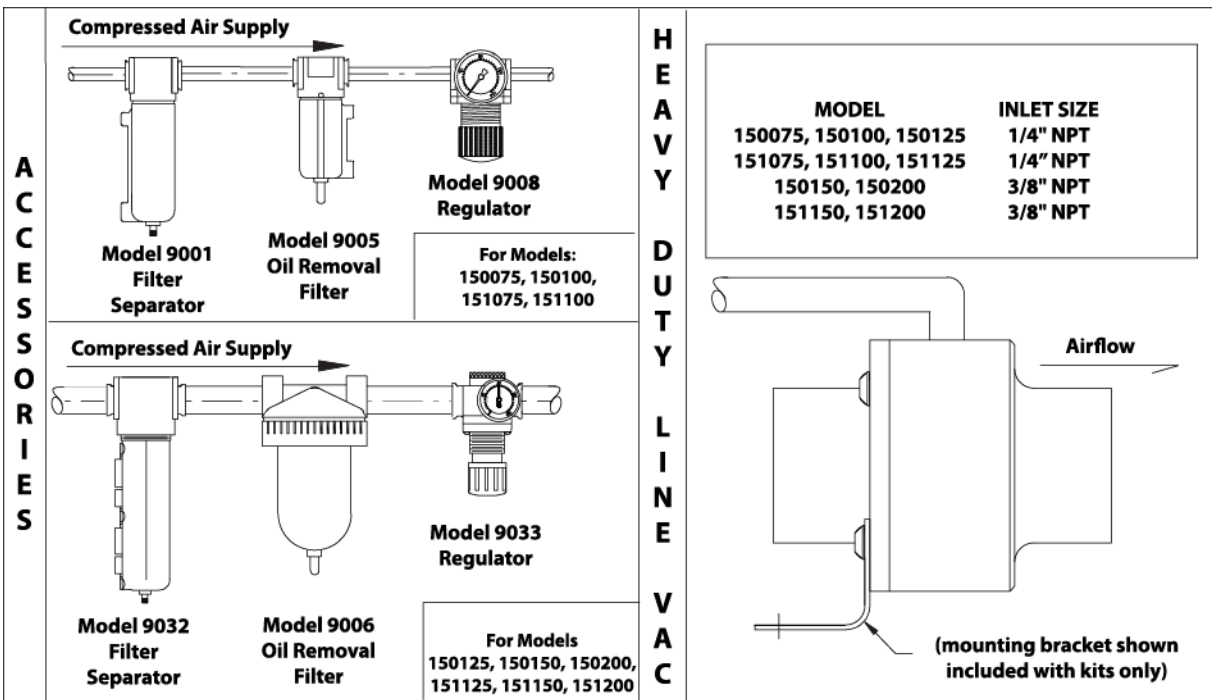

COMPRESSED AIR LINE SIZES

For Heavy Duty Line Vac Models 150075-150125 and HD Threaded Models 151075 – 151125, use 1/4" pipe or 3/8" hose for runs up to 25' (7.6m) long. For runs up to 50' (15.2m), use 3/8" pipe or 1/2" hose and for runs over 50' (15.2m), use 1/2" pipe or larger. For Heavy Duty Line Vac Models 150150 – 150200, and HD Threaded Models 151150 and 151200, use 1/2" pipe or larger. Do not use restrictive fittings or undersized lines that can “starve” the Heavy Duty Line Vac by causing excessive line pressure drop.

COMPRESSED AIR SUPPLY

With proper filtration and separation of dirt, moisture and oil from the compressed air supply, the Heavy Duty Line Vac will operate for years with no maintenance required.

Use a 10 micron or smaller filter separator on the compressed air supply (Model 9001 Automatic Drain Filter Separator for Models 150075, 150100, 151075 and 151100; Model 9032 Automatic Drain Filter Separator for Heavy Duty Models 150125 – 150200 and HD Threaded Models 151125 – 151200).

To prevent problems associated with oil, use an oil removal filter (Model 9005 Oil Removal Filter for Models 150075, 150100, 151075 and 151100; Model 9006 Oil Removal Filter for Heavy Duty Models 150125 – 150200 and HD Threaded Models 151125 – 151200). The oil removal filter should be used downstream from the automatic drain filter separator. Filters should be used close to each Heavy Duty Line Vac, within 10 to 15' (3 to 4.6m) is best.

The Heavy Duty Line Vac is designed to use normal shop air supplies up to 100 PSIG (6.9 BAR, 689 kPa). For infinite control of flow (conveying speed), pressure may be regulated using Model 9008 Pressure Regulator for Models 150075, 150100, 151075 and 151100; Model 9033 Pressure Regulator for Heavy Duty Models 150125-150200 and HD Threaded Models 151125 –151200. Maximum pressure is 250 PSIG (17.2 BAR, 1.72 MPa).

If air preparation units other than EXAIR models are being used, please note the following:

- **PRESSURE REGULATORS** – Must be pressure relieving and rated for a supply pressure of 250 PSIG (17.2 BAR, 1.72 MPa). Suggested operating pressure is 5-125 PSIG (0.3-8.6 BAR, 34-862 kPa). For models 2" (51mm) and under, flow should be minimum 50 SCFM (1416 SLPM). For models over 2" (51mm) and up to 4" (102mm), flow should be minimum 90 SCFM (2549 SLPM). For models over 4" (102mm), flow should be minimum 150 SCFM (4248 SLPM).

- **AUTO DRAIN FILTER SEPARATORS** – Must be rated for a supply pressure of 250 PSIG (17.2 BAR, 1.72 MPa) and have 25 micron filtration. For models 2” (51mm) and under, flow should be minimum 50 SCFM (1416 SLPM). For models over 2” (51mm) and up to 4” (102mm), flow should be minimum 90 SCFM (2549 SLPM). For models over 4” (102mm), flow should be minimum 150 SCFM (4248 SLPM).
- **OIL REMOVAL FILTERS** – Must be rated for a supply pressure of 250 PSIG (17.2 BAR, 1.72 MPa) and have 0.03 micron filtration. For models 2” (51mm) and under, flow should be minimum 50 SCFM (1416 SLPM). For models over 2” (51mm) and up to 4” (102mm), flow should be minimum 90 SCFM (2549 SLPM). For models over 4” (102mm), flow should be minimum 150 SCFM (4248 SLPM).

USING HEAVY DUTY LINE VAC

Mounting brackets are available for the Heavy Duty Line Vac (included with kits only). In some cases, the Heavy Duty Line Vac will be supported by the compressed air supply pipe.

Heavy Duty Line Vac units are made in various sizes to be used with standard hose, tube or pipe (choose a material that resists wear). They perform best when mounted at the suction point, however, a hose, tube or pipe can be attached to either or both ends of the unit. The hose, tube or pipe should be straight when possible and bends minimized to reduce back pressure.

WARNING: Do not use with any material that can create an explosive mixture.

HOW THE HEAVY DUTY LINE VAC WORKS

Compressed air flows through the inlet (1) into an annular plenum chamber (2). It is then injected into the throat through directed nozzles (3). These jets of air create a vacuum at the intake (4) which draws material in and accelerates it through the unit (5) at long vertical or horizontal distances.

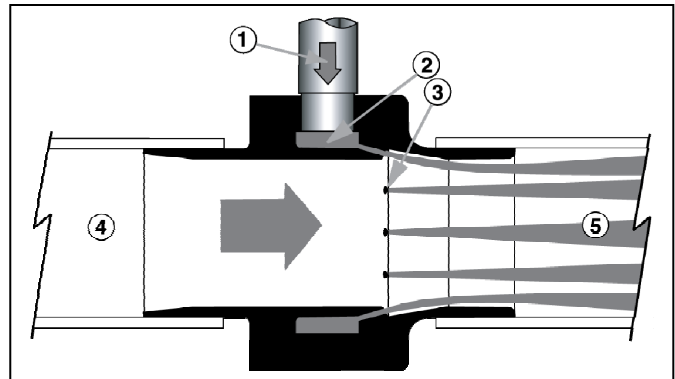

ADJUSTING THE HEAVY DUTY LINE VAC

The flow generators have a series of holes that convey the material. These holes should never be drilled out. Performance has already been maximized. Conveying speed can be controlled with a pressure regulator.

TROUBLESHOOTING & MAINTENANCE

If there is a reduction in flow or vacuum from the Heavy Duty Line Vac, check the pressure by installing a gauge at the compressed air inlet of the Heavy Duty Line Vac. Large pressure drops are possible due to undersized lines, restrictive fittings and clogged filter elements.

For replacement or repair filter and regulator parts, contact EXAIR at 1-800-903-9247 or techhelp@exair.com. Call (513) 671-3322 for outside the US and Canada.

CLEANING

If contaminants have clogged the Heavy Duty Line Vac, remove all screws to disassemble the unit. Inspect each part for dirt contamination and a possible oil film on the flow generator. Clean each part and reassemble. The Heavy Duty Line Vac consists of a body, a flow generator, two O-rings and a cap that holds the flow generator in place. The screws that hold the assembly together are on the intake side of the unit. When reassembling, the small holes of the flow generator should point to the exhaust end.

Occasionally, there is a build up which occurs in the throat of the Heavy Duty Line Vac as a result of vapors in the atmosphere. Clean the surface with a solvent and a clean rag. To prevent contaminants from getting pushed back into the generator holes, perform this procedure with a small amount of compressed air passing through the Heavy Duty Line Vac.

If you have any questions or problems, please contact an EXAIR Application Engineer at:

Toll Free: 1-800-903-9247 (U.S. & Canada)
 Telephone: 513 671-3322 outside of U.S. & Canada
 Toll Free Fax: 866-329-3924 (U.S. & Canada)
 FAX: 513 671-3363 outside of U.S. & Canada
 E-mail: techhelp@exair.com
 Website: www.exair.com

For more information about this product, visit
 "Frequently Asked Questions" at www.exair.com
FAQ at www.EXAIR.com